

**TAKE UP EXISTING KERB, BED AND BACKING**

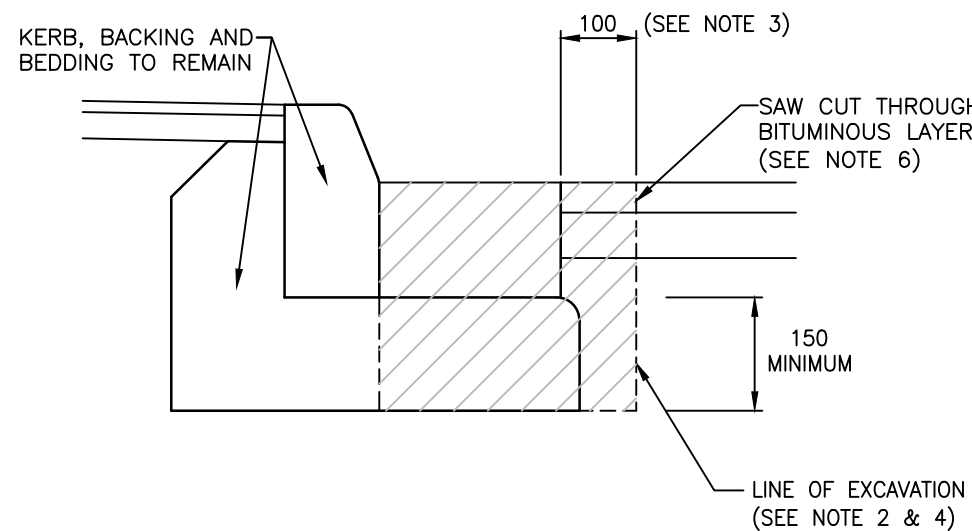

**TAKE UP EXISTING CHANNEL AND BED**

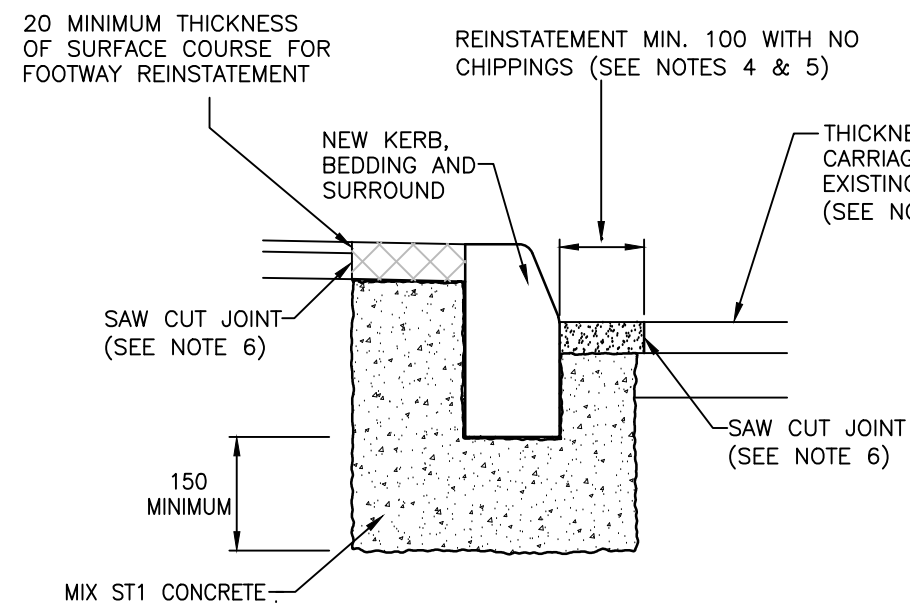

**REPLACEMENT KERB LAID ON NEW BASE**

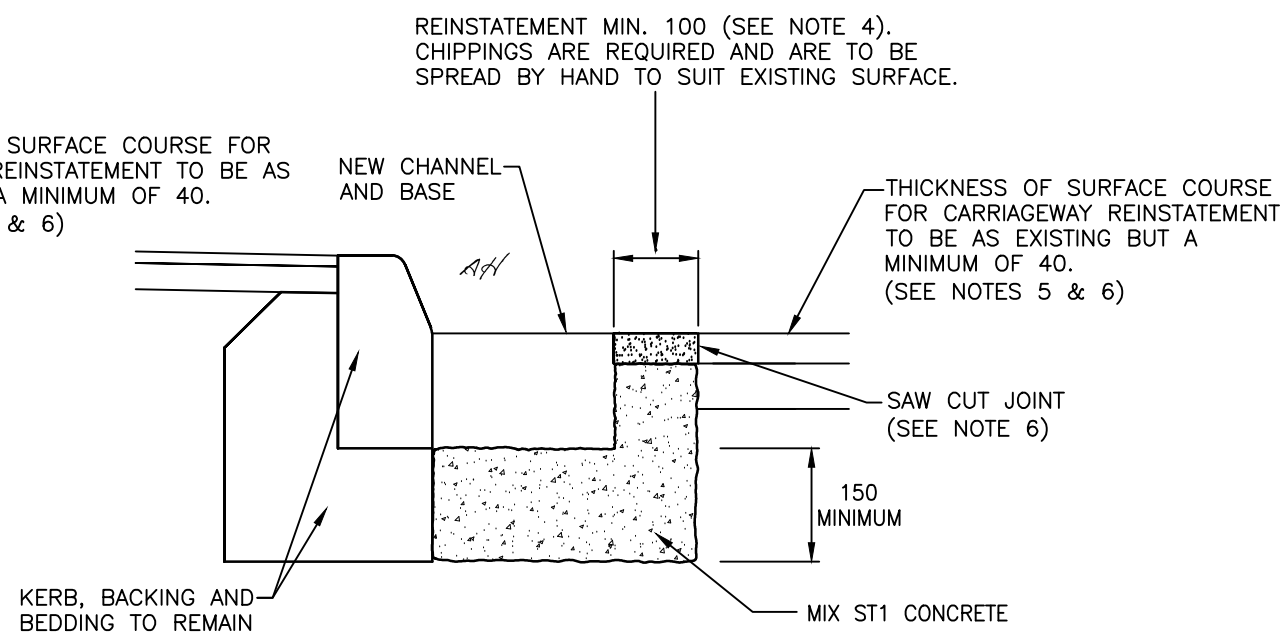

**REPLACEMENT CHANNEL LAID ON NEW BASE**

IF CHANNEL BLOCKS ARE NOT REPLACED, NO PRE COATED CHIPPINGS SHALL BE USED WITHIN THE FIRST 250mm OF REINSTATEMENT. ELSEWHERE, PRE COATED CHIPPINGS SHALL HAVE A MIN. PSV OF 60.

**NOTES:**

1. ALL DIMENSIONS ARE IN MILLIMETRES.
2. EXISTING CARRIAGEWAY AND/OR FOOTWAY PAVEMENT CONSTRUCTION SHALL BE CUT VERTICAL TO CLEAN LINE AND FACE.
3. THE BREAK OUT IN FRONT OF THE KERB OR CHANNEL MAY BE OMITTED WHERE CARRIAGEWAY RESURFACING IS TO BE CARRIED OUT AT THE SAME TIME AS KERB REPLACEMENT.
4. WHERE EXISTING KERB BED EXTENDS MORE THAN 100 INTO THE CARRIAGEWAY, THE BREAK OUT SHALL BE EXTENDED AS REQUIRED TO ENSURE ALL OF KERB BED IS REMOVED. REINSTATEMENT OF SURFACE COURSE TO BE PROPORTIONALLY INCREASED. WHERE THIS ENCROACHES INTO THE WHEEL TRACK IT SHALL BE EXTENDED FURTHER TO AVOID THE AREA.
5. REINSTATEMENT MATERIAL SHALL BE HRA 15/10F SURF 40/60 TO BS EN 13108-4. PRE COATED CHIPPINGS TO BE USED WHERE CHANNEL BLOCKS ARE REPLACED SHALL BE MINIMUM 60 PSV. THE MINIMUM WIDTH OF REINSTATEMENT SHALL BE 100 AND THE MAXIMUM WIDTH SHALL BE 300 UNLESS NOTE 4 ABOVE APPLIES WITH REGARD TO WHEEL TRACK LOCATION.
6. TREATMENT OF LAYERS AND VERTICAL SURFACES SHALL BE IN ACCORDANCE WITH CL 903.4. THE BOND COAT SHALL BE IN ACCORDANCE WITH APPENDIX 7/4.

REV	AMENDMENTS	DATE	CAD	CHKD	APPD

CONSULTANT

STUART JARVIS BSc DipTP FCIHT MRTPI: DIRECTOR OF ECONOMY, TRANSPORT & ENVIRONMENT

**STANDARD DETAILS**

**KERB REPLACEMENT (ON NEW BASE)**

HCC CADplot: 28.Feb.2020 at 11:01am		
DRAWN MC	CHECKED AH	SCALE @ A3 N.T.S
CAD MC	APPROVED SDG	DATE March 2020
DRG No. HCC11/M/010	REVISION	

Copyright Hampshire County Council. 2019  
All rights, including translation, reserved. No part of this publication may be reproduced, stored in a retrieval system, or transmitted in any form or by any means (electronic, mechanical, photocopied, recorded or otherwise) without the prior written permission of Hampshire County Council. Requests should be directed to the Economy, Transport & Environment Department.

Use only in conjunction with the Standard Details (Scheme) as indicated. Dec 2011 LCC11 2020 STANDARD DETAILS (Scheme) 010.dwg