

DETAIL C
SCALE 1:5

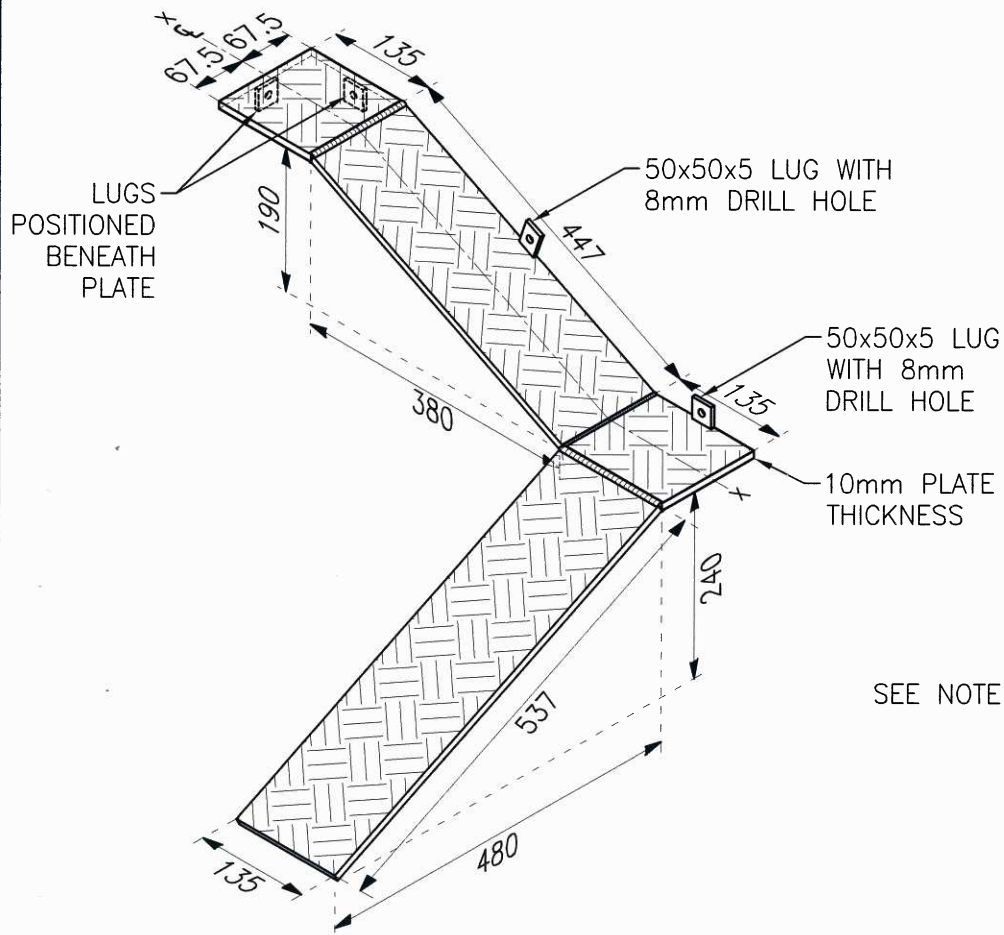

DETAIL E —
ANIMAL ESCAPE RAMP
SCALE 1:10

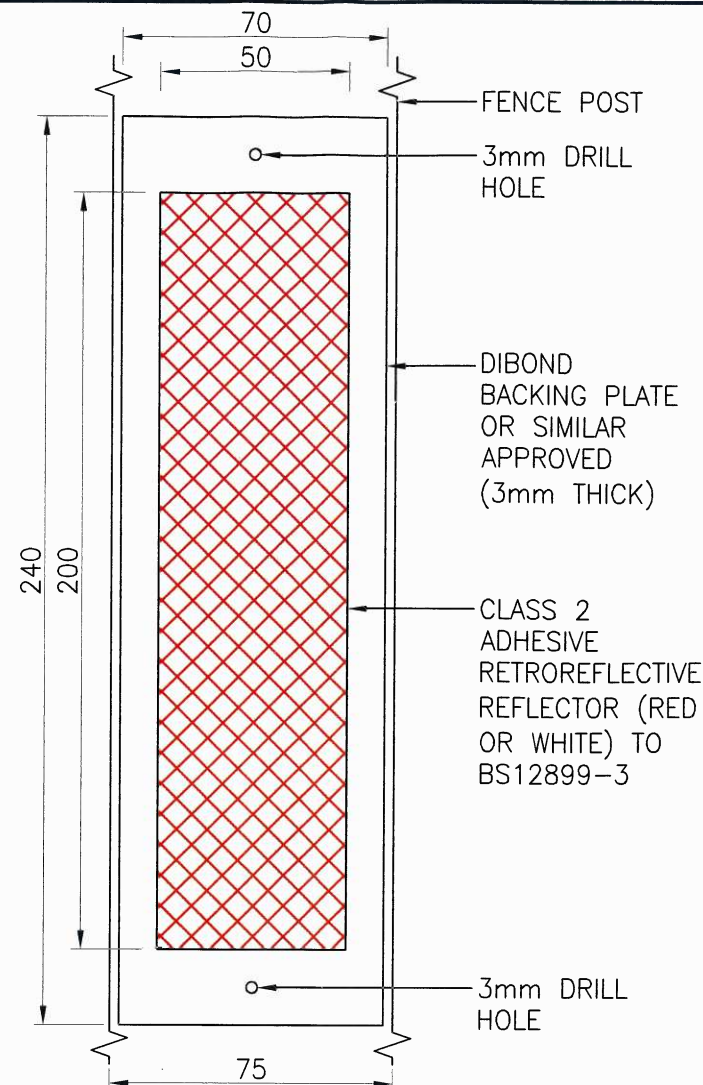

DETAIL D
SCALE 1:2

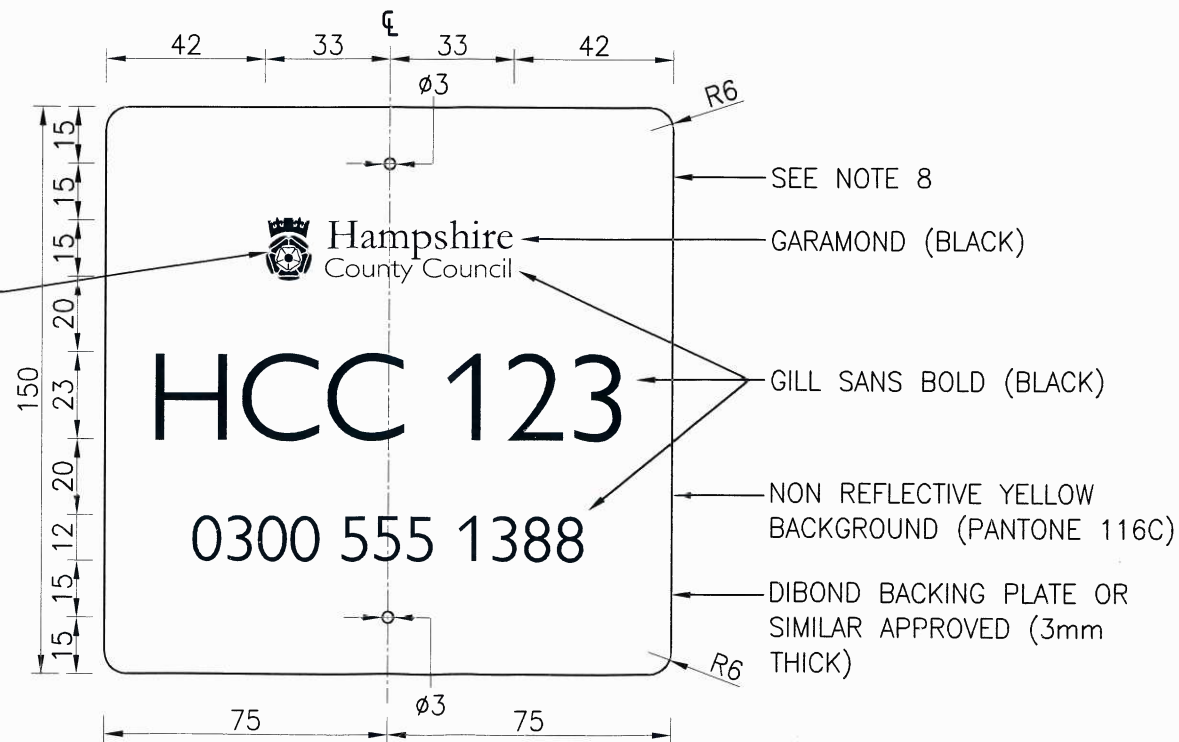

DETAIL F —
CATTLE GRID PLATE
SCALE 1:2

8. THE LOCATION OF THE CATTLE GRID PLATES (2 No) SHALL BE DESCRIBED IN THE WORKS INFORMATION AND FIXED USING GALVANISED SCREWS.
9. THE HCC CREST (INCLUDING ROSE) SHALL BE BLACK.

NOTES:

1. DO NOT SCALE FROM THIS DRAWING.
2. ALL DIMENSIONS ARE IN MILLIMETRES UNLESS OTHERWISE STATED.
3. THE FENCE POSTS SHALL BE CENTRED AT 1400mm. REFER TO HCC10/C/136 FOR MOUNTING HEIGHTS OF THE 5 HORIZONTAL RAILS. REFER TO DETAIL C FOR SECURING THE POSTS TO THE CONCRETE.
4. RETROREFLECTIVE REFLECTORS SHALL BE MOUNTED TO THE FENCE POSTS USING GALVANISED SCREWS. THE CENTRE OF THE REFLECTORS SHALL BE POSITIONED 900mm ABOVE THE SIDE WALLS.
5. DETAIL E SHOWS THE ANIMAL ESCAPE RAMP (2 No) FOR POSITIONING INTO THE LEFT HAND SIDE OF THE GRID ADJACENT TO EACH END WALL. ITS MIRROR IMAGE ALONG X-X SHALL BE ACCEPTABLE FOR POSITIONING INTO THE RIGHT HAND SIDE IF APPROPRIATE.
6. THE ANIMAL ESCAPE RAMP SHALL BE FABRICATED FROM STAINLESS STEEL WITH SINGLE SIDED BUTT WELDS AND A MINIMUM THROAT THICKNESS OF 4mm. THE TOP SURFACES SHALL HAVE A CHEQUER SURFACE WITH 1D MILL FINISH. SUPPORTING LUGS SHALL BE WELDED USING A 4MM FILLET WELD. THE ANIMAL ESCAPE RAMP SHALL BE SECURED USING HILTI STANDARD HOT-DIP GALVANISED STUD ANCHORS HSA-F M6x50 5/-/- OR SIMILAR APPROVED.
7. THE CONTRACTOR SHALL LAY A 400mm HIGH MESH ONTO EACH END FENCE POST AND ALONG THE LENGTH OF THE BOTTOM 2 FENCE RAILS TO CONTAIN LIVE STOCK. THE WIRE MESH SHALL BE 50mmx50mm GALVANISED WELDED MESH, 10 GAUGE.

REV	AMENDMENTS	DATE	CAD	CHKD	APPD
-	-	-	-	-	-

CONSULTANT

STUART JARVIS BSc DipTP FCIHT MRTPI: DIRECTOR OF ECONOMY, TRANSPORT & ENVIRONMENT

SCHEME

STANDARD DETAILS

DRAWING TITLE

PRECAST CATTLE GRID
ANCILLARY DETAILS

HCC CADplot: 24.Aug.2015 at 3:34pm

DRAWN	CHECKED	SCALE @ A3
RAH	JB	AS SHOWN
CAD	APPROVED	DATE
AC	PW	JULY 2015
DRG No.	REVISION	
HCC10/M/130	-	

Copyright Hampshire County Council. 2015

All rights, including translation, reserved. No part of this publication may be reproduced, stored in a retrieval system, or transmitted in any form or by any means (electronic, mechanical, photocopied, recorded or otherwise) without the prior written permission of Hampshire County Council. Requests should be directed to the Economy, Transport & Environment Department.