

CARRIAGEWAY REPAIR TYPE A1

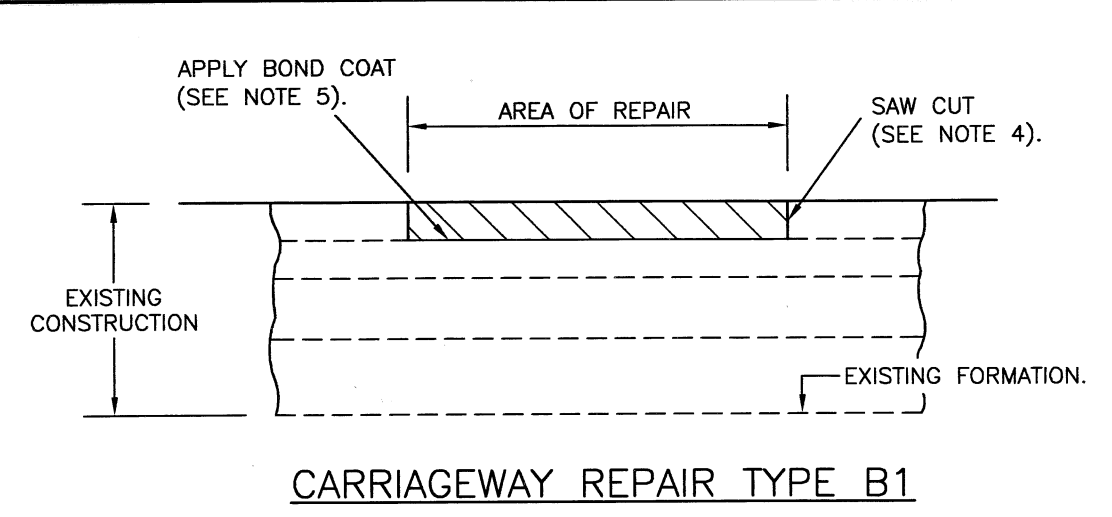

CARRIAGEWAY REPAIR TYPE B1

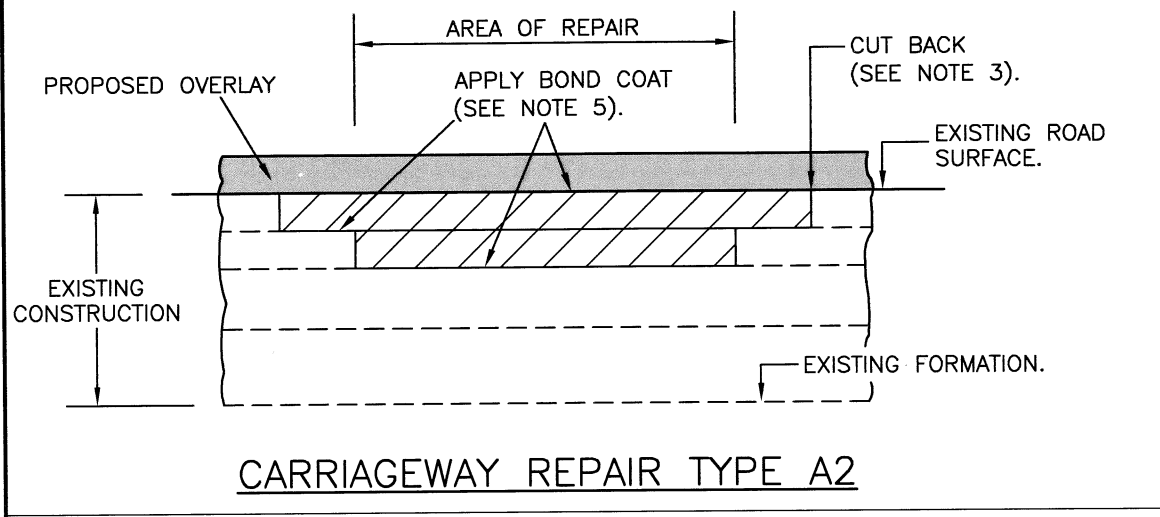

CARRIAGEWAY REPAIR TYPE A2

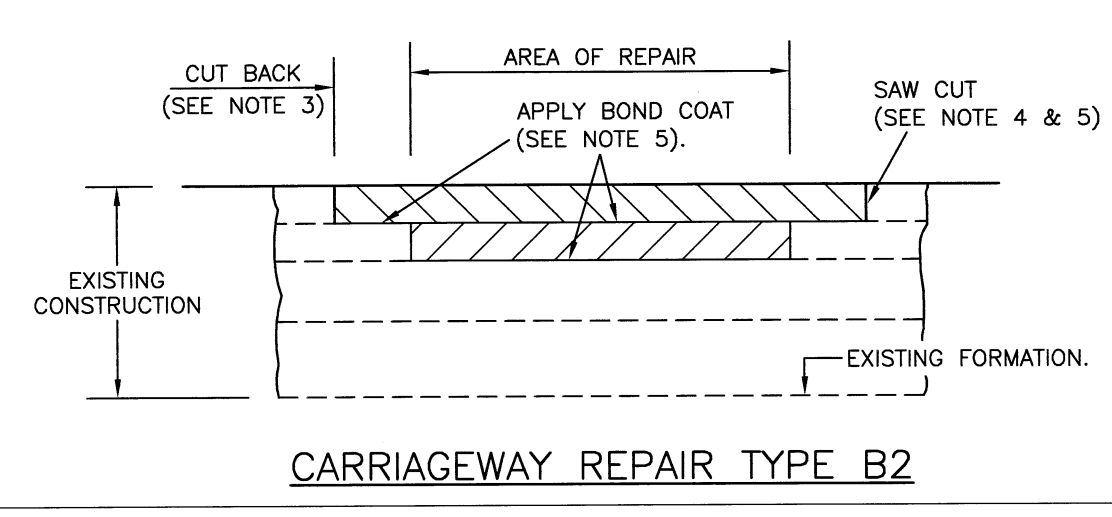

CARRIAGEWAY REPAIR TYPE B2

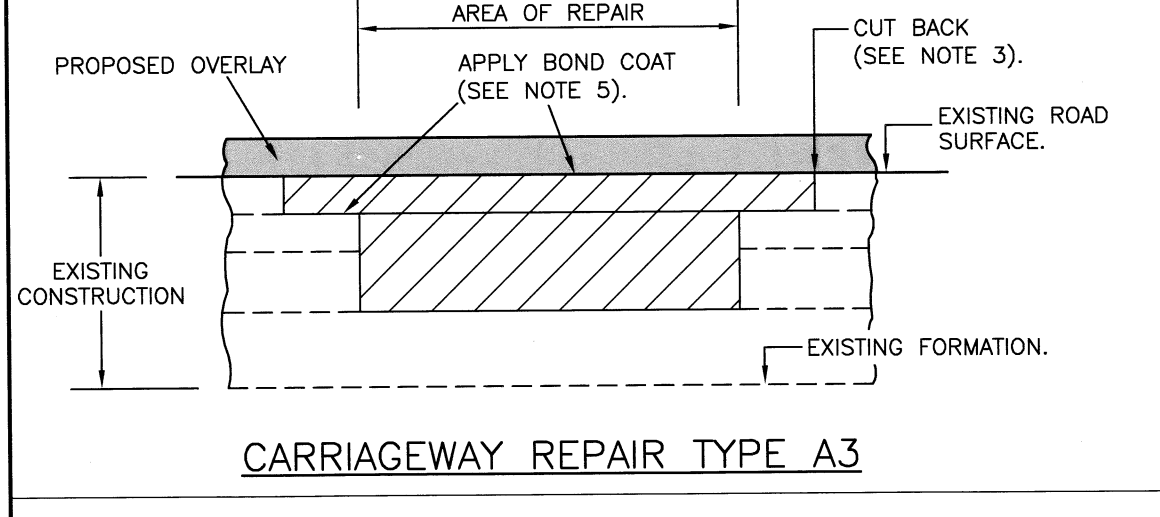

CARRIAGEWAY REPAIR TYPE A3

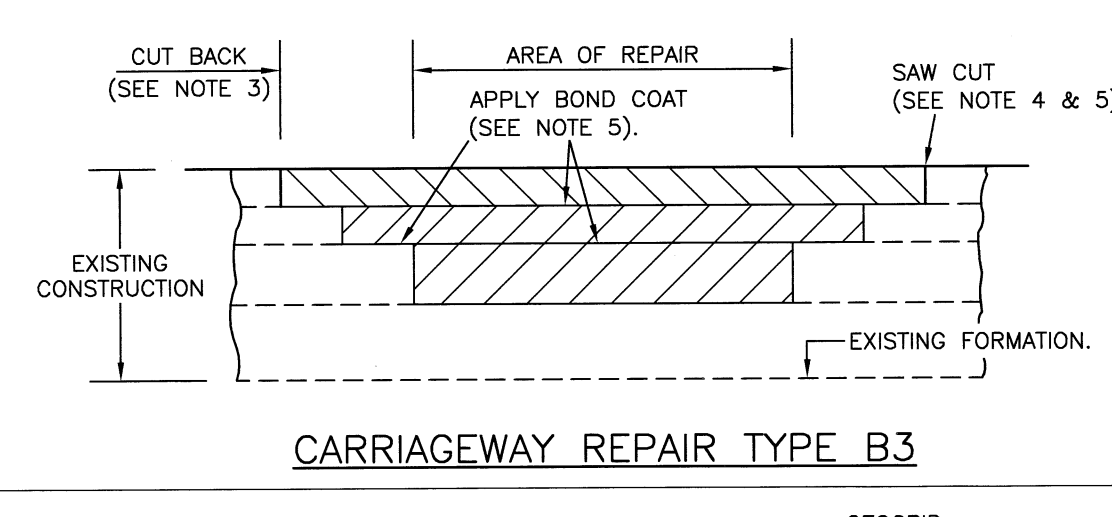

CARRIAGEWAY REPAIR TYPE B3

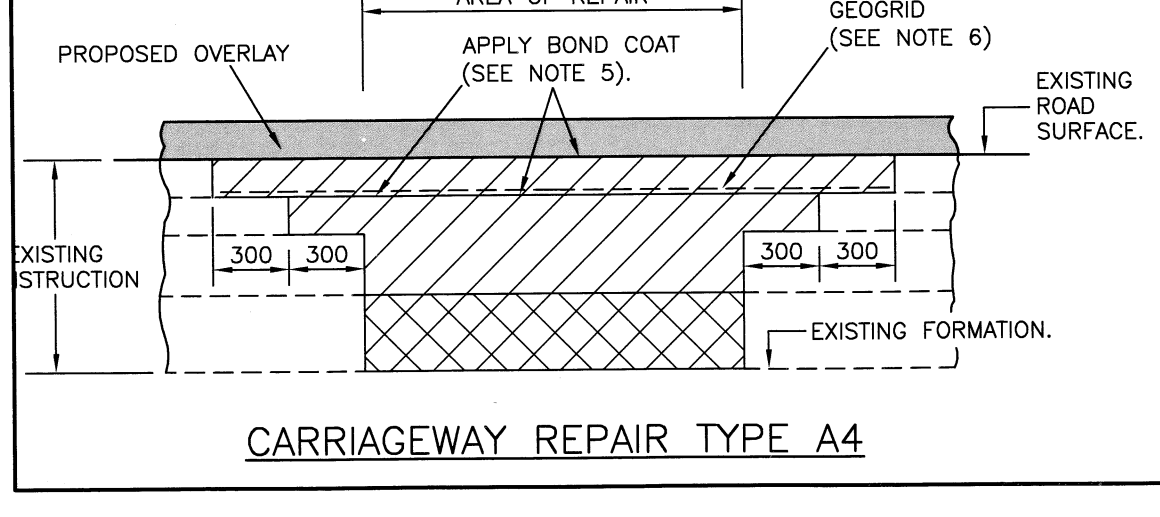

CARRIAGEWAY REPAIR TYPE A4

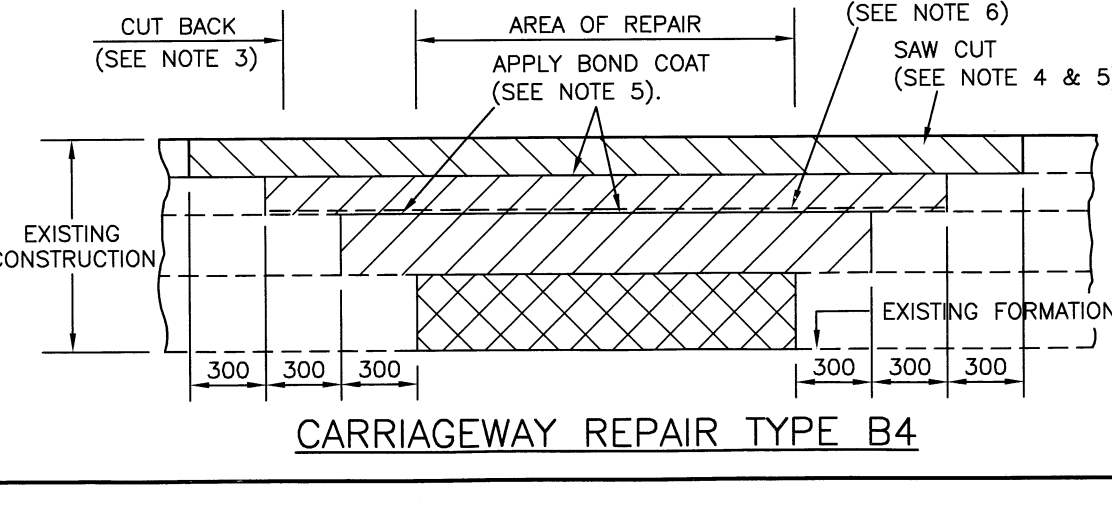

CARRIAGEWAY REPAIR TYPE B4

- NOTES:**
1. ALL DIMENSIONS ARE IN MILLIMETRES.
 2. **LEGEND.**
 - PROPOSED OVERLAY.
 - SURFACE COURSE MATERIAL AS DETAILED IN APPENDIX 7/1.
 - BINDER/BASE MATERIAL AS DETAILED IN APPENDIX 7/1.
 - SUBBASE TO CLAUSE 803, 891AR, 892AR, 893AR OR 894AR QH AS DETAILED IN APPENDIX 7/1.
 3. THE WIDTH OF CUT BACK SHALL BE AS SPECIFIED IN APPENDIX 7/2.
 4. SAW CUT AROUND THE AREA TO BE RECONSTRUCTED TO AT LEAST THE DEPTH OF SURFACE COURSE LAYER.
 5. TREATMENT OF LAYERS AND VERTICAL SURFACES SHALL BE IN ACCORDANCE WITH CL. 903.4. THE BOND COAT SHALL BE IN ACCORDANCE WITH APPENDIX 7/4.
 6. UNLESS OTHERWISE STATED IN APPENDIX 7/2 REPAIR TYPES A4 AND B4 SHALL HAVE GLASS FIBRE STRESS ABSORBING MEMBRANE (GEOGRID) INSTALLED BENEATH THE BINDER LAYER SPANNING THE EDGE OF THE REPAIR BY 300 EITHER SIDE. THE COMPOSITE GEOGRID SHALL HAVE A MINIMUM TENSILE STRENGTH IN BOTH DIRECTIONS OF 100kN/m. INSTALLATION IN ACCORDANCE WITH MANUFACTURER'S INSTRUCTIONS.

Copyright Hampshire County Council. 2015
 All rights, including translation, reserved. No part of this publication may be reproduced, stored in a retrieval system, or transmitted in any form or by any means (electronic, mechanical, photocopied, recorded or otherwise) without the prior written permission of Hampshire County Council. Requests should be directed to the Economy, Transport & Environment Department.

REV	AMENDMENTS	DATE	CAD	CHKD	APPD
-	-	-	-	-	-

CONSULTANT

Hampshire County Council **Engineering CONSULTANCY**

STUART JARVIS BSc DipTP FCILT MRTPI DIRECTOR OF ECONOMY, TRANSPORT & ENVIRONMENT

SCHEME

STANDARD DETAILS

DRAWING TITLE

CARRIAGEWAY REPAIR DETAILS

HCC CADplot: 18.Sep.2015 at 2:14pm	SCALE @ A3
DRAWN MC	CHECKED WW
CAD MC	APPROVED CP
DRG No. HCC10/M/025	REVISION -

N.T.S.
July 2015