

'Standard' Rigid Bus  
 Overall Length 12.000m  
 Overall Width 2.550m  
 Overall Body Height 3.069m  
 Min Body Ground Clearance 0.309m  
 Track Width 2.350m  
 Lock to Lock Time 4.00s  
 Wall to Wall Turning Radius 10.771m

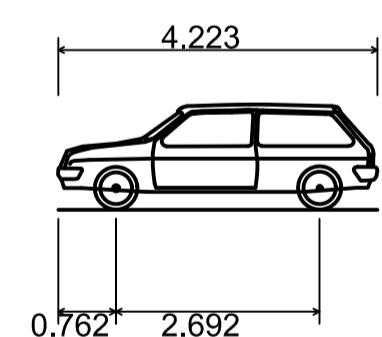

DB32 Private Car  
 Overall Length 4.223m  
 Overall Width 1.715m  
 Overall Body Height 1.392m  
 Min Body Ground Clearance 0.233m  
 Max Track Width 1.629m  
 Lock to Lock Time 4.00s  
 Kerb to Kerb Turning Radius 5.780m

© CROWN COPYRIGHT AND DATABASE RIGHTS 2015  
 ORDNANCE SURVEY 100019180

CLIENT <b>HAMPSHIRE COUNTY COUNCIL</b> ECONOMY, TRANSPORT AND ENVIRONMENT DEPARTMENT STRATEGIC TRANSPORT		CONSULTANT  STUART JARVIS BSc DipTP FCIHT MRTPI: DIRECTOR OF ECONOMY, TRANSPORT & ENVIRONMENT		DESIGNER RW CAD AI CHECKED LW APPROVED CM	SCHEME NEWGATE LANE SOUTHERN SECTION JOB No. CJ007861.001 SCALE @ A1 1:100 DATE 22.10.2015 SHEET NUMBER 1 OF 1	DRAWING TITLE SWEEP PATH PASSED BUS HCC CAD PLOT: 23/10/2015 15:12:53 DRAWING NUMBER <b>EC/CJ007861/044</b>	REV
REV	AMENDMENTS	DATE	CAD	CHKD	APPD		